



MARPAC K SERIES

Full Bore Fire Safe Flanged Ball Valves



Experience In Motion

The Flowserve Marpac flanged full bore valve range provides customers with specification compliant product with long service free life resulting in low cost of ownership. All valves comply with the requirements of ASME B.16.34 with a one piece design up to 1½” and the two piece design extending the range from 2” to 8”

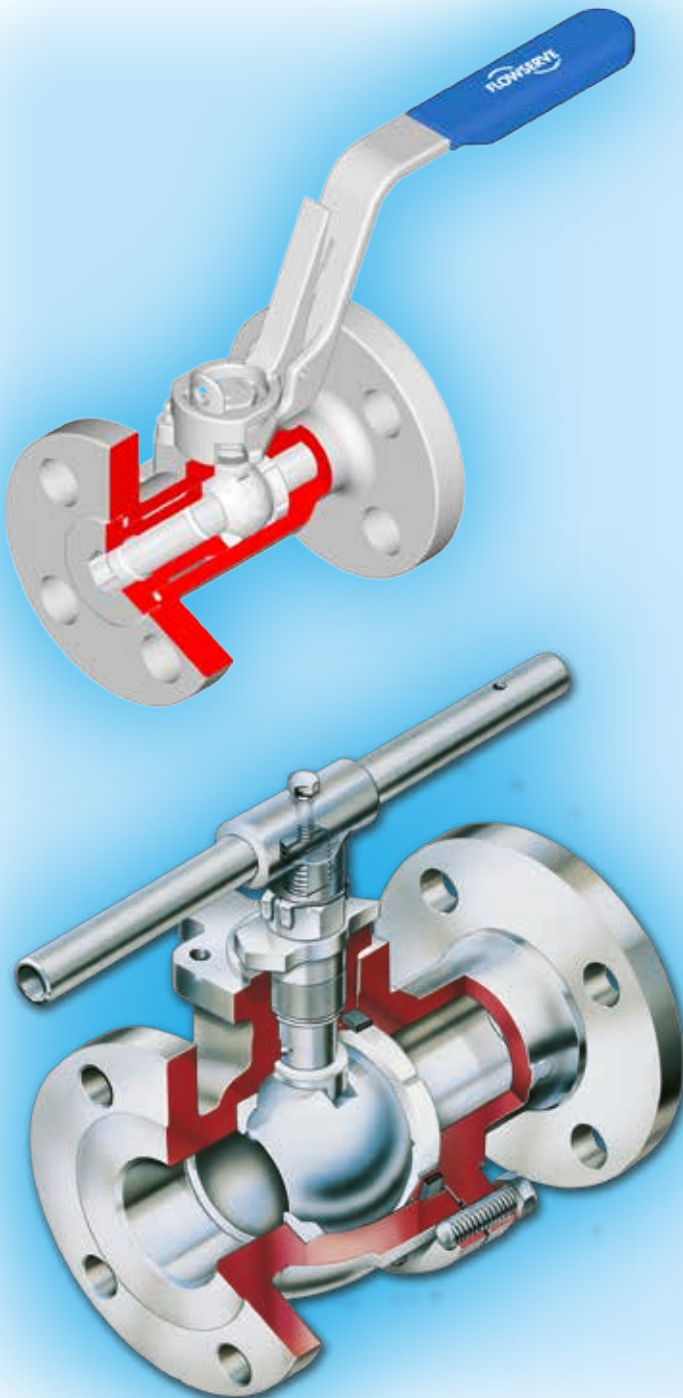

Anti-blowout stem

Inserted from inside of valve body for greater safety

Actuator Mounting

Conforms to ISO 5211 for ease of actuation

Anti-static stem design

Ensures electrical continuity between ball and body

Ball

Parallel ported 316 stainless steel as standard with pressure equalizing hole to balance cavity pressure when the valve is open

Body seals

PTFE with metal to metal secondary seal on one-piece valves and PTFE coated graphite on two piece eliminating potential media contamination whilst providing fire rated integrity

Gland packing

Graphite provides fire rated integrity and combined with the body seals ensures Fugitive Emission compliance to ISO 15848

Wrench

Ergonomically designed tamper proof lockable design on one-piece valves and multi position fit wrench on two-piece valves to suit space requirements

Locking clip

Maintains position of gland nut during actuation for long leak-free performance

Actuation

Valve assembled ready for actuation with no changes to stem build required maintaining valve integrity

Bolting

Stainless steel as standard meeting the requirements of ASME VIII Div 1 pressure vessel codes

Locking Device

Tamper proof design ensures the padlock cannot be removed or over-ridden when locked either open or closed (North America & Canada only)

Parts/Materials List

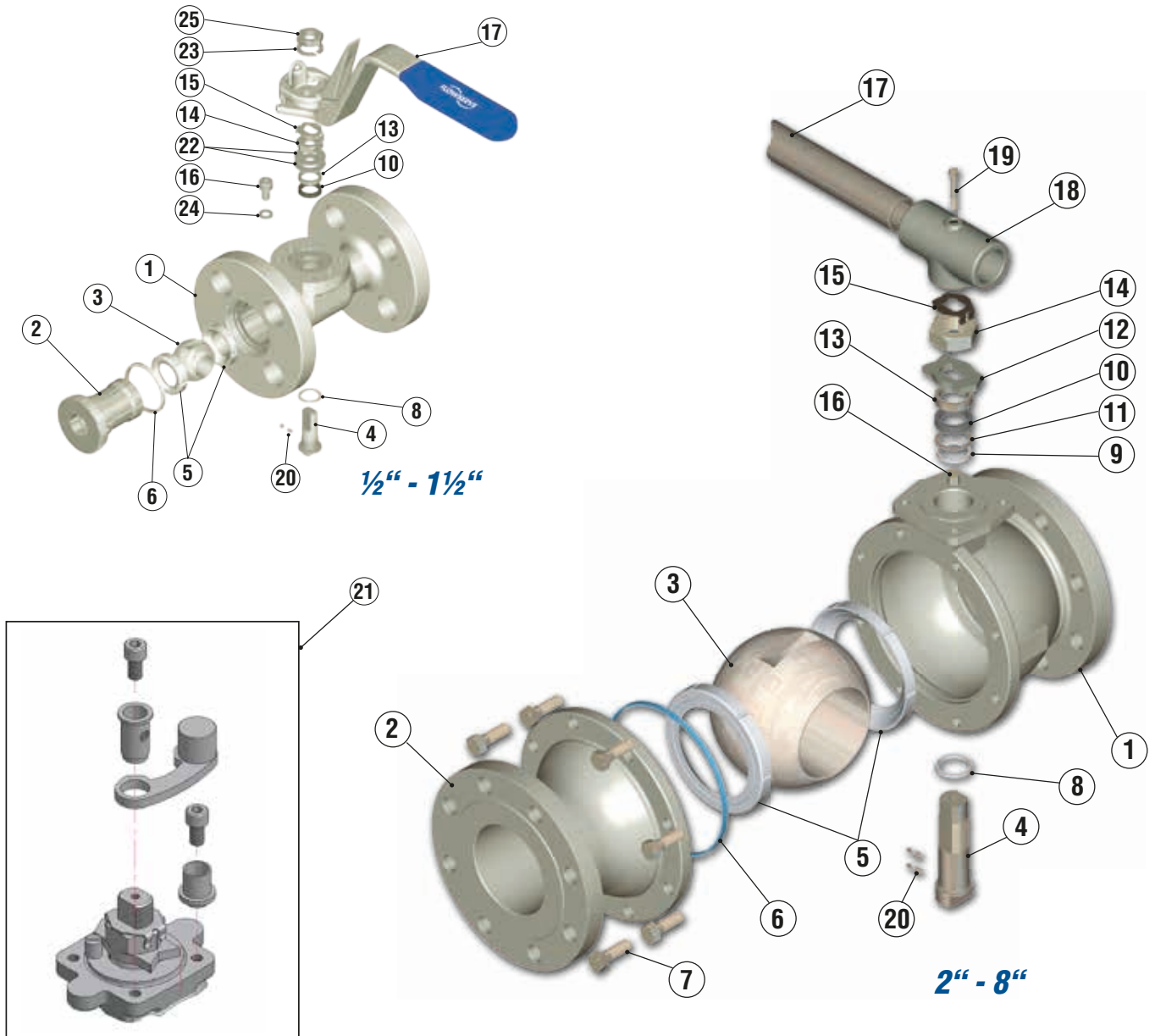

Item	Description	Material	Item	Description	Material
1 & 2	Body & Insert/Connector	Stainless Steel ASTM-A351 CF8M Low Temp Carbon Steel ASTM-A352 LCB	14	Gland nut	Zinc Plated Stainless Steel
3	Ball	Stainless Steel A479 316, ASTM-A351 CF8M	15	Gland Nut Locking Clip	Stainless Steel
4	Stem	Stainless Steel A479 316	16	Stop Pin	Stainless Steel
5	Seat	TFE Virgin, Polyfill (see page 6)	17	Wrench	Stainless Steel, Carbon Steel
6	Body Seal	PTFE / PTFE Coated Flexible Graphite	18	Wrench Head	Stainless Steel, Carbon Steel
7	Body Connector Screw	Stainless Steel ASTM A193M, B8 CL2/B8M CL2	19	Wrench attachment Bolt	Stainless Steel, Carbon Steel
8	Stem Thrust Seal	TFE, Polyfill	20	Anti-static Spring & Plunger	Stainless Steel
9	Secondary Stem Seal	TFE	21	Locking /device	Stainless Steel
10	Gland Packing	TFE, Flexible Graphite	22	Washer	Stainless Steel
11	Stem Location Ring	Stainless Steel 316	23	Lockwasher	Stainless Steel
12	Indicator Stop	Stainless Steel	24	Washer	Stainless Steel
13	Gland	Stainless Steel 316	25	Nut	Stainless Steel

Valve Dimensions 1/2" to 1 1/2" inch/mm

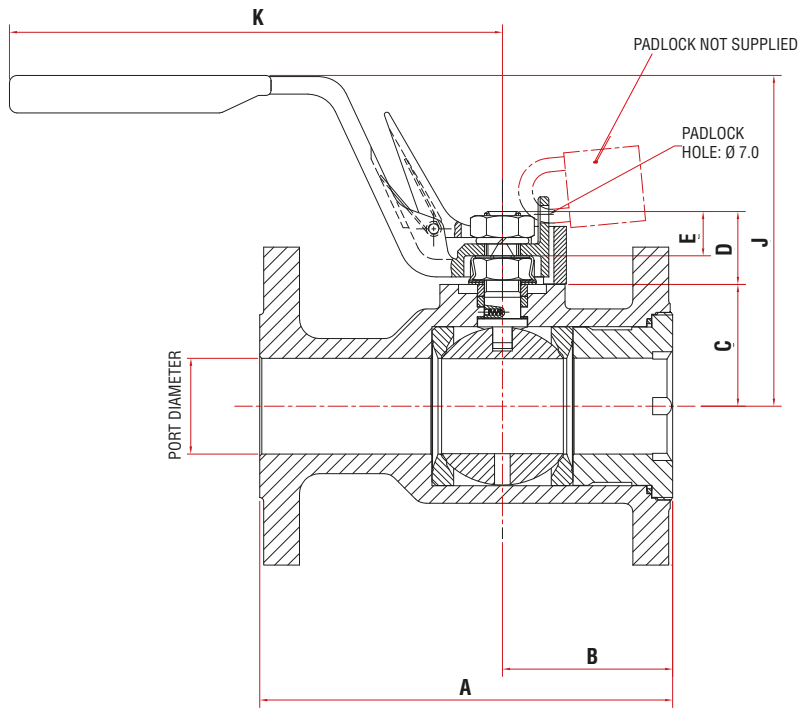
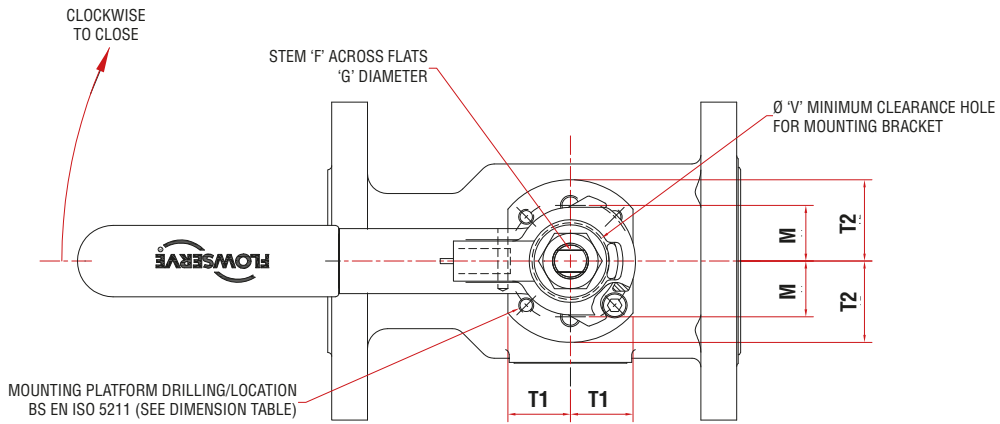

Valve Size	Port Dia. Min.	A		B	C	D	E	Stem		J	K	M	T1	T2	V	Mounting Platform			
		KFP1	KFP3					F	G							ISO Size	PCD	Thread	Depth Min
1/2"	0.54	4.25	5.5	2.07	0.916 0.906	0.691 0.664	0.421 0.401	0.218 0.215	3/8"-24 UNF	3.74	6.10	0.63	0.75	0.91	0.77	F03	1.42	M5	0.31
DN15	13.7	108.0	140.0	52.5	23.27 23.01	17.56 16.86	10.69 10.19	5.54 5.46	3/8"-24 UNF	95.0	155.0	15.9	19.0	23.0	19.5	F03	36.0	M5	8.0
3/4"	0.79	4.61	6.0	2.24	1.273 1.263	0.935 0.902	0.598 0.578	0.297 0.294	7/16"-20 UNF	4.17	6.61	0.81	0.87	1.06	0.89	F04	1.65	M5	0.31
DN20	20.0	117.0	152.0	57.0	32.34 32.08	23.76 22.92	15.19 14.69	7.54 7.47	7/16"-20 UNF	105.8	168.0	20.7	22.0	27.0	22.5	F04	42.0	M5	8.0
1"	1.00	5.00	6.5	2.48	1.461 1.451	0.935 0.902	0.598 0.578	0.297 0.294	7/16"-20 UNF	4.35	6.61	0.81	0.87	1.06	0.89	F04	1.65	M5	0.31
DN25	25.3	127.0	165.0	63.0	37.11 36.85	23.74 22.90	15.19 14.69	7.54 7.47	7/16"-20 UNF	110.5	168.0	20.7	22.0	27.0	22.5	F04	42.0	M5	8.0
1 1/2"	1.48	6.50	7.5	2.68	1.920 1.909	1.163 1.130	0.724 0.704	0.343 0.340	9/16"-18 UNF	5.19	7.76	0.88	0.98	1.28	1.16	F05	1.97	M6	0.39
DN40	37.7	165.0	190.0	68.0	48.76 48.50	29.55 29.71	18.39 17.89	8.71 8.64	9/16"-18 UNF	131.7	197.0	22.3	25.0	32.5	29.5	F05	50.0	M6	10.0

Valve Dimensions 2" to 8" inch/mm

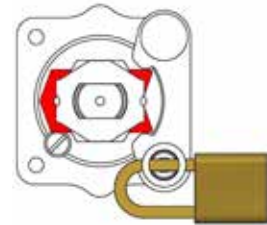
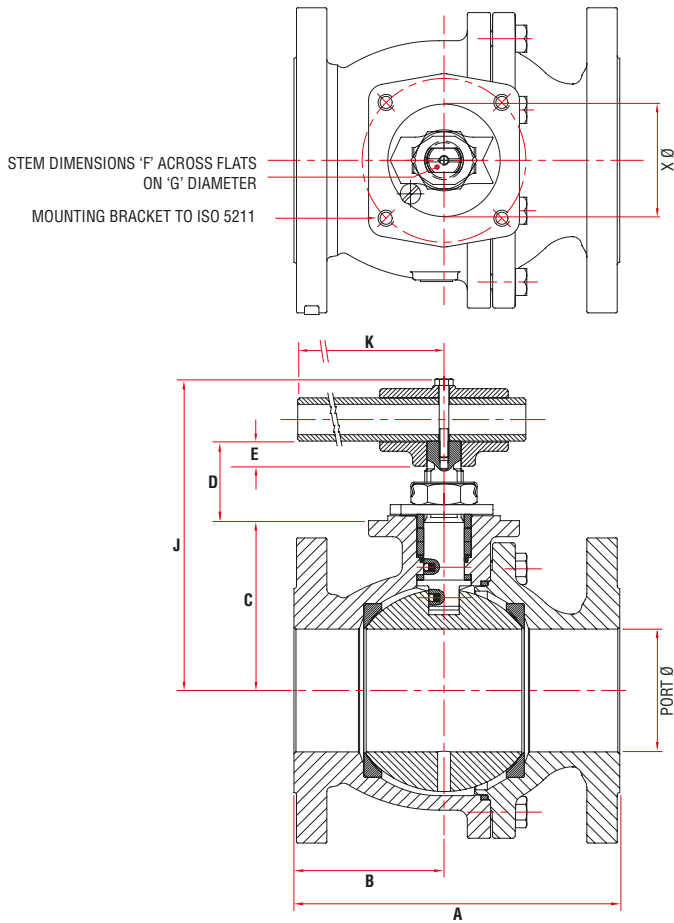

Locked Open*

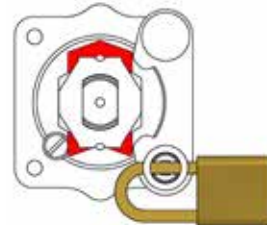

Locked Closed*

* Padlock not supplied with valve.

		KFP1 (ASME Class 150)										KFP3 (ASME Class 300)													
Valve Size	Port Dia. Min.	A	B	C	D	E	F		G	J	K	X Dia.	ISO Size	A	B	C	D	E	F		G	J	K	X Dia.	ISO Size
							A/F Max.	Dia. Max.											A/F Max.	Dia. Max.					
2"	2.0	7.0	2.91	3.45 3.42	1.72 1.63	0.52	0.55	0.79	6.14	8.86	2.17	F07	8.5	2.9	3.45 3.42	1.72 1.63	0.52	0.55	0.79	6.14	8.86	2.17	F07		
DN50	51.1	178.0	74.0	87.6 86.9	43.8 41.5	13.1	14.0	20.0	156.0	225.0	55.0	F07	216.0	74.0	87.6 86.9	43.8 41.5	13.1	14.0	20.0	156.0	225.0	55.0	F07		
3"	3.0	8.0	3.70	4.43 4.39	2.01 1.91	0.66	0.59	0.83	7.91	13.78	2.17	F07 F10	11.0	3.7	4.72 4.69	2.19 2.09	0.83	0.76	1.07	8.43	21.93	2.76	F10		
DN80	76.5	203.0	94.0	112.4 111.6	51.1 48.4	16.8	15.1	21.2	201.0	350.0	55.0	F07 F10	283.0	93.5	119.9 119.1	55.7 53.0	21.0	19.3	27.2	214.0	557.0	70.0	F10		
4"	4.0	9.0	4.61	5.54 5.50	2.20 2.09	0.86	0.76	1.07	9.25	21.93	2.76	F10	12.0	5.2	5.79 5.76	2.87 2.78	1.11	1.05	1.31	10.83	33.46	3.35	F12		
DN100	102.3	229.0	117.0	140.6 139.8	55.9 53.2	21.8	19.3	27.2	235.0	557.0	70.0	F10	305.0	132.0	147.1 146.3	73.0 70.3	28.2	26.6	33.2	275.0	850.0	85.0	F12		
6"	6.0	15.5	7.05	7.18 7.15	2.87 2.77	1.11	1.05	1.30	12.20	33.46	3.35	F12	16.0	7.0	7.66 7.63	3.05 2.94	1.15	1.20	1.49	12.87	33.46	3.94	F14		
DN150	152.0	394.0	179.0	182.4 181.6	73.0 70.3	28.2	26.6	33.1	310.0	850.0	85.0	F12	403.0	179.0	194.6 193.8	77.4 74.7	29.2	30.4	37.9	327.0	850.0	100.0	F14		
8"	8.0	18.0	8.11	9.35 9.31	3.04 2.94	1.15	1.20	1.49	-	-	3.94	F14	20.0	9.1	10.09 10.05	3.48 3.37	1.38	1.36	1.68	-	-	5.12	F16		
DN200	203.3	457.0	206.0	237.4 236.6	77.4 74.7	29.2	30.4	37.9	-	-	100.0	F14	502.0	231.0	256.2 255.3	88.4 85.5	35.0	34.5	42.6	-	-	130.0	F16		

Pressure/Temperature Ratings

TFE SEATS (T)

Virgin PTFE is the most common sealing material and is suitable for almost all media as it has excellent chemical resistance.

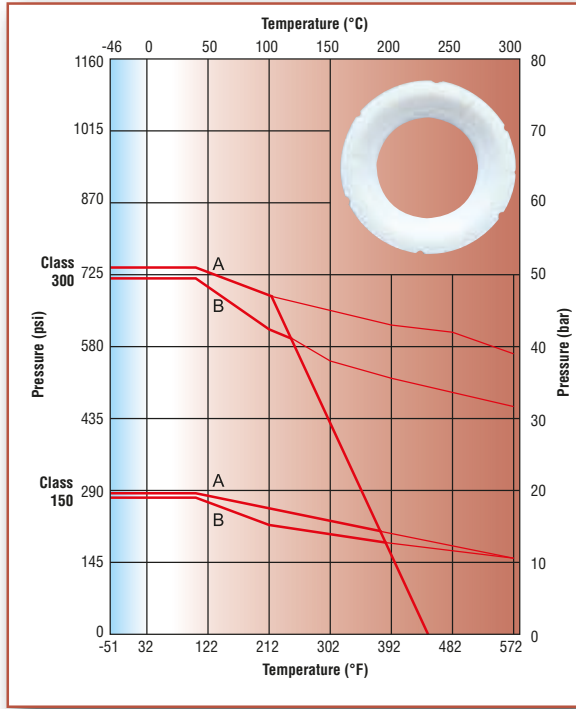

POLYFILL (5)

Carbon and graphite filled TFM material an excellent seat material for higher pressure and temperature applications.

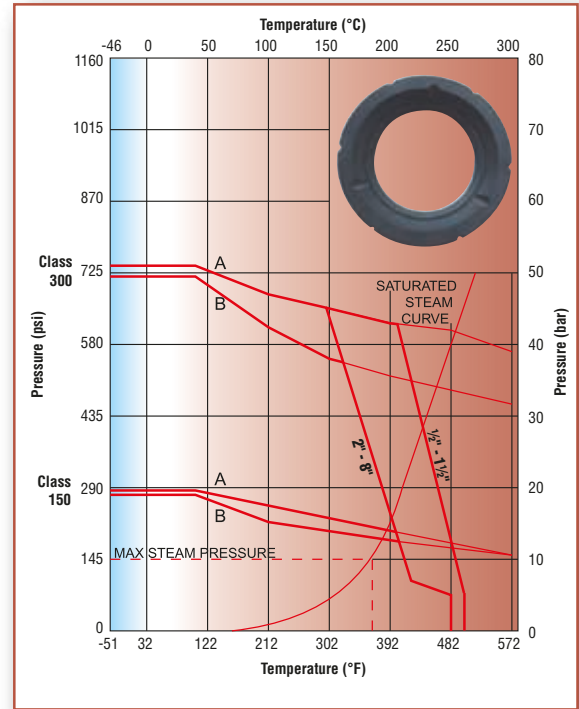

KEY: A = Carbon steel body rating B = Stainless steel body rating

Pressure Torque Curves

TFE & POLYFILL SEATS

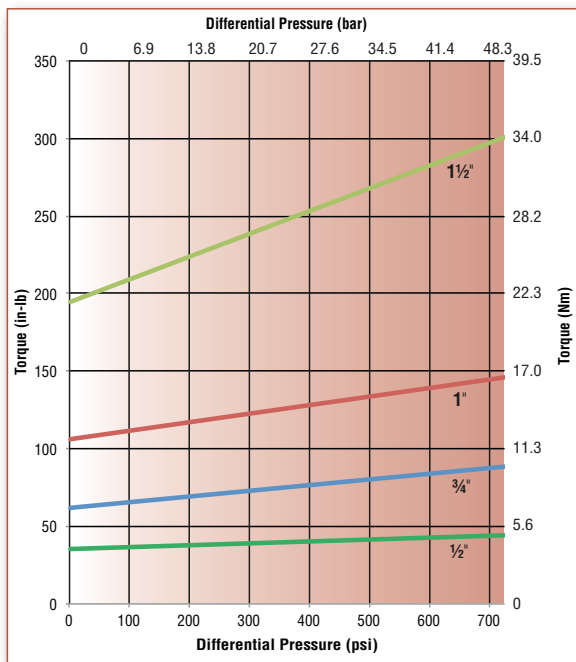

TFE & POLYFILL SEATS

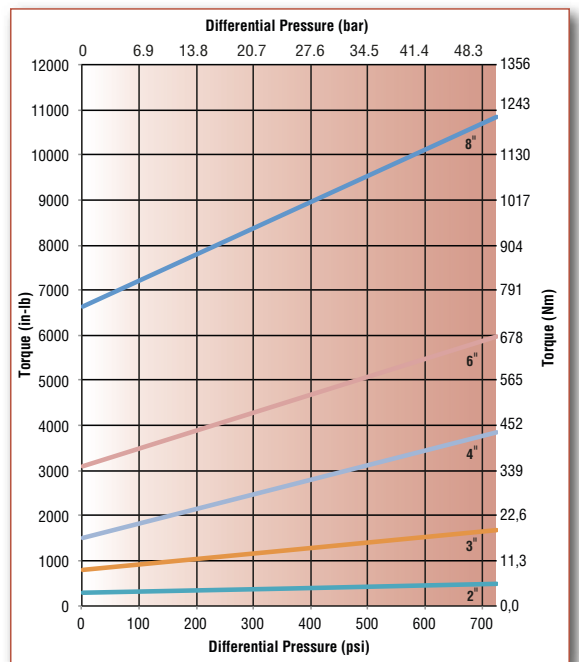

Note: Please apply safety factors as recommended in the Worcester Controls Actuator Sizing Manual

Standards of Compliance

Valve Specification	ASME B.16.34 / ISO 17292	Fire rating	API 607 ISO 10497 (Graphite build only)
Face to Face Lengths	KFP1 (Class 150) ASME B16.10 Column 19 Short ½" - 4" ASME B16.10 Column 18 Long 6" - 8" EN558 Table 2 Series 3½" - 4" EN558 Table 2 Series 12 6" - 8"	Pressure Test	API 598
	KFP3 (Class 300) ASME B16.10 Column 8 Short ½" - 6" ASME B16.10 Column 7 Long 8" EN558 Table 2 Series 4 ½" - 6"	Fugitive Emission	EN 15848 (Graphite build only)
Quality Assurance	ISO 9001	Sour Gas Applications	NACE MR.01.75 / ISO 15156 (Internal Only)
Marking	MSS-SP25	Flanges	ASME B.16.5 Class 150 & 300 BS EN 1759-1 Class 150 & 300

Technical Information

Valve Size	Series	Weight		Limiting Stem Torque		Flow Coefficients	
		lbs	Kg	lb-in	Nm	Cv	Kv
½" DN15	KFP1	4.0	1.8	69	7.8	32	27
	KFP3	4.9	2.2	69	7.8	32	27
¾" DN20	KFP1	5.3	2.4	157	17.7	54	46
	KFP3	7.7	3.5	157	17.7	54	46
1" DN25	KFP1	7.1	3.2	157	17.7	94	80
	KFP3	10.1	4.6	157	17.7	94	80
1½" DN40	KFP1	12.8	5.8	299	33.8	254	219
	KFP3	19.0	8.6	299	33.8	254	219
2" DN25	KFP1	26.5	12.0	1042	118	501	423
	KFP3	33.1	15.0	1042	118	501	423
3" DN25	KFP1	48.5	22.0	1838	208	1158	978
	KFP3	70.5	32.0	3083	348	1158	978
4" DN25	KFP1	88.2	40.0	3080	348	2118	1789
	KFP3	125.7	57.0	6774	765	2118	1789
6" DN25	KFP1	194.0	88.0	6774	765	5074	4287
	KFP3	257.9	117.0	10100	1141	5074	4287
8" DN25	KFP1	388.0	176.0	10100	1141	9337	7889
	KFP3	520.3	236.0	14503	1639	9337	7889

Cv - Flow in US GPM Pressure psi Kv - Flow in M3/hr Pressure - bar

How to Order (Typical)

A - Size		B - Series		C - Body Material		D - Seat		E - Seal		F - Ball & Stem	
½" 15mm	224	K-Series Class 150	KFP1	Low temp Carbon St.	C3	Virgin TFE	T	TFE	T	Stainless Steel (316)	S6
¾" 20mm	225	K-Series Class 300	KFP3	Stainless Steel	S6	Polyfill	5	Graphite	F		
1" 25mm	226										
1½" 40mm	228										
2" 50mm	229										
3" 80mm	231										
4" 100mm	232										
6" 150mm	234										
8" 200mm	235										

Example: 232 KFP3 S6 5 T S6

Ordering Example: A 4" Series KFP3 full port flanged valve with stainless steel body, 316 stainless steel ball and stem, Polyfill seats, TFE body seal, ANSI Class 300 flanges. Note: Standard McCANNA/MARPAC valves are assembled with silicon based break-in lubricant. For other options, consult your distributor or Flowserve.

▲ CAUTION: Ball valves can retain pressurized media in the body cavity when closed. Use care when disassembling. Always open valve to relieve pressure prior to disassembly.



Flowserve Corporation
Flow Control Division
1978 Foreman Drive
Cookeville, Tennessee
38501 USA
Telephone: +931 432 4021
Fax: +931 432 5518

Contact:

For more information about Flowserve Corporation, visit www.flowserve.com or call USA 1-800-225-6989.

FCD MMENBR1030-00 AQ 09/16 Printed in USA.

Flowserve Corporation has established industry leadership in the design and manufacture of its products. When properly selected, this Flowserve product is designed to perform its intended function safely during its useful life. However, the purchaser or user of Flowserve products should be aware that Flowserve products might be used in numerous applications under a wide variety of industrial service conditions. Although Flowserve can (and often does) provide general guidelines, it cannot provide specific data and warnings for all possible applications. The purchaser/user must therefore assume the ultimate responsibility for the proper sizing and selection, installation, operation, and maintenance of Flowserve products. The purchaser/user should read and understand the Installation Operation Maintenance (IOM) instructions included with the product, and train its employees and contractors in the safe use of Flowserve products in connection with the specific application.

While the information and specifications contained in this literature are believed to be accurate, they are supplied for informative purposes only and should not be considered certified or as a guarantee of satisfactory results by reliance thereon. Nothing contained herein is to be construed as a warranty or guarantee, express or implied, regarding any matter with respect to this product. Because Flowserve is continually improving and upgrading its product design, the specifications, dimensions and information contained herein are subject to change without notice. Should any question arise concerning these provisions, the purchaser/user should contact Flowserve Corporation at any one of its worldwide operations or offices.

© 2016 Flowserve Corporation, Irving, Texas, USA. Flowserve and Worcester Controls are registered trademarks of Flowserve Corporation.